

# G2427 S180

Printed Matter No. 9836 9907 00

Die grinder

Valid from Serial No. A5700001  
2014-05-01

## Product Instructions

G2427-S180 ( 18000 r/min)

8423031287



### WARNING

**Read all safety warnings and instructions**  
*Failure to follow the safety warnings and instructions may result in electric shock, fire and/or serious injury.*  
**Save all warnings and instructions for future reference**

**Atlas Copco**

# Table of Contents

EN Product Instructions.....	3
------------------------------	---

# Safety and operating instructions

## General information

### Design and function

This die grinder is intended for mounted wheels and rotary burrs only. This model is lubricated. The machine, its attachments and accessories must only be used for the purpose for which they were designated, all other use is prohibited.

- Never use grinding wheels attached with an adapter as this machine is not fitted with a wheel guard
- Never attach circular saw blades or other cutters than the abrasive wheels or brushes specified for the tool

### Signs and stickers

The product is fitted with signs and stickers containing important information about personal safety and product maintenance. The signs and stickers shall always be easy to read. New signs and stickers can be ordered by using the spare



s011050

## Installation

### Installation

- Fit the support handle in suitable position for right- or left hand operation respectively.
- Always make sure that you have the correct guard for the grinding equipment.
- Attach the grinding equipment.  
Adjust the guard for best operator protection.
- Connect the machine to the air line.  
Blow out the hose before connecting.  
The motor requires no additional lubrication during operation.
- The throttle valve lever may only be activated after pushing the lever catch release arm forwards.

 Check regularly that the catch and the release arm moves easily.

### Installation of vibrating tools

It is recommended that a minimum length of 300 mm of flexible hose for compressed air is inserted between a vibrating tool and the quick-action coupling.

### Air quality

- For optimum performance and maximum product life we recommend the use of compressed air with a dew point between +2°C and +10°C. Installation of an Atlas Copco refrigeration-type air dryer is recommended.

- Use a separate air filter of type Atlas Copco FIL, removes solid particles larger than 15 microns and more than 90 % of liquid water, installed as close as possible to the product and prior to any other air preparation unit like REG or DIM (please see Air Line Accessories in our main catalogue). Blow out the hose before connecting.

#### Lubricated models:

- The compressed air must contain a small quantity of oil. We strongly recommend that you install an Atlas Copco oil-fog lubricator DIM, to be set normally at 3–4 drops (50 mm<sup>3</sup>)/min for long cycle running tools, or an Atlas Copco single-point lubricator type Dosol for short cycle running tools. For Dosol setting please see Air Line Accessories in our main catalogue.

### Compressed air connection

#### ⚠ WARNING Air under pressure can cause serious injury

- ▶ Always shut off air supply, drain hose of air pressure and disconnect tool from air supply when not in use, before making any adjustments to the product, e.g. changing accessories, or when making repairs.
- ▶ Never direct air at yourself or anyone else.

#### ⚠ WARNING Whipping hoses can cause serious injury

- ▶ Always check for damaged or loose hoses and fittings.

#### Check air pressure:

- The product is designed for a working pressure (e) of 6–7 bar = 600–700 kPa = 87–102 psig.
- The air pressure at the tool inlet with the product running must not exceed the maximum operating pressure 7 bar – 700 kPa – 102 psig.
- Blow out the hose before connecting it.

### Installation proposal

To save time and to ensure correct capacity of the airline installation, from the tapping point to the tool, we offer you an installation proposal.

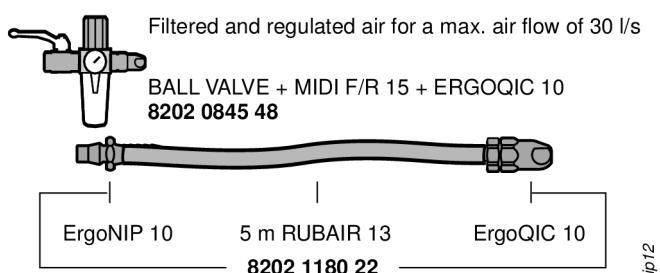

Do not use quick disconnect couplings at tool.

Whenever universal twist couplings are used, lock pins must be installed.

For more information please read, Atlas Copco Industrial Power Tools catalogue Ordering No. 9837 3000 01.

### Operation

See also Service instructions

## Preparations before using the die grinder

### **Correct function of die grinder**

#### **⚠ WARNING Overspeed can result in serious injury or death**

- ▶ The maximum permissible speed as marked on the machine must not be exceeded

Testing of the die grinder should only be carried out by professional technicians. The technicians must be authorized to test this type of tool and to operate a pneumatic system in accordance with national directives.

- The free speed of the machine shall be checked every day and whenever the machine has been serviced. This check should be carried out with the grind-

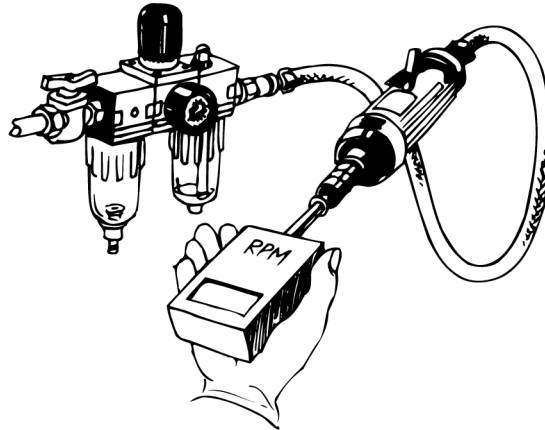

s011370

ing equipment detached

- Use a pressure regulator to avoid excessive air pressure which may cause overspeed
- Connections and air hose must be in good condition

### **Mounted wheel and carbide burr**

#### **⚠ WARNING Air under pressure can cause serious injury**

- ▶ Always shut off air supply, drain hose of air pressure and disconnect tool from air supply when not in use, before making any adjustments to the machine, e.g. changing accessories, or when making repairs

#### **⚠ WARNING Wrong insert tool can burst and cause serious injury or death**

- ▶ Use insert tool with max operating speed higher or equal to the airgrinder speed
- ▶ Do not use other insert tool than specified by the manufacturer (no cutting off wheels or router bits).
- Use only recommended sizes and types of abrasives
- Do not use mounting wheels that are chipped or cracked, or may have been dropped
- Correct mounting is necessary to prevent injury from broken mounted wheels
- Ensure the shaft diameter of the accessory is correct for the size of collet
- Do not mix mm shanks with inch collets and vice versa
- Observe a min of 10 mm axial grip of the shank

- When fitting mounted wheels or burrs, reduce the overhang by pushing the shank all the way into the collet (Check also the recommendations given by the tool manufacturer)
- Observe that increased overhang of shank reduces permissible speed
- Before starting the machine, check that the collet is properly tightened
- Test run every new mounted wheel in a safe position for 30 seconds. Be sure to use a barrier (such as under a heavy work table) to stop any possible broken wheel parts. Stop immediately if vibration is excessive



### Correct working with the die grinder

Read the Section Safety instructions before using the die grinder.



s011390

### ⚠ **WARNING Failure to follow correct working practices can result in serious injury or death**

- ▶ Ensure that the workpiece is properly supported
- ▶ Ensure that sparks do not cause a hazard to people or materials
- ▶ There is a risk of electrostatic discharge if the tool is used on plastic and other non-conductive materials
- ▶ Personal protective equipment must be used as described in Section Personal protective equipment
- ▶ Slip/Trip/Fall is a major cause of serious injury or death. Watch out for excess hose left on the walking or work surface
- ▶ Proceed with care in unfamiliar surroundings. Hidden hazards may exist, such as electric or other utility lines
- ▶ Maintain a balanced body position and firm footing
- ▶ React quickly to excessive vibration due to damaged, or improperly mounted insert tool
- ▶ Keep away from rotating drive spindle and abrasives. Rotation may continue for several seconds after the throttle has been released. Do not lay the tool down until rotation has stopped
- ▶ Observe that stored compressed air in the hose may cause an accidental start
- ▶ Release control device if the energy supply should fail

## **Maintenance**

### **Rust protection and internal cleaning**

Water in the compressed air, dust and wear particles cause rust and sticking of vanes, valves etc.

This can be solved by lubricating with oil (a few drops), running the machine for 5-10 seconds and wiping off excess oil with a cloth. **Do this before longer standstills.**

### **Lubrication**

The front motor ball bearing should be lubricated with grease in conjunction with the regular overhaul of the machine.

**For flexible spindle extension** – When fitting the extended spindle – apply 0.5 cm<sup>3</sup> of grease type “Lubricating Engineers LE3752” (or EP grease) at the bottom of the hole in the collet holder.

### **Lubricating guide**

Use lubricants of good quality. The oils and greases listed in the lubrication table are examples of lubricants that can be recommended.

<b>Brand</b>	<b>General purpose</b>	
	<b>Bearings</b>	<b>Air lubrication</b>
BP	Energrease LS-EP2	Energol E46
Castrol	Spheerol EP L2	

Brand	General purpose	
	Bearings	Air lubrication
Esso	Beacon EP2	Arox EP46
Q8	Rembrandt EP2	Chopin 46
Mobil	Mobilegrease XHP 222	Almo oil 525
Shell	Alvania EP2	Tonna R32
Texaco	Multifak EP2	Aries 32
Molycote	BR2 Plus	

## Overhaul

### **⚠ WARNING Overspeed could result in serious injury or death**

- ▶ If governor is used, check that correct governor is assembled. Careless handling may put it out of order
- ▶ Do not disassemble security parts, e.g. speed governor or overspeed shut-off. These parts must be completely replaced when damaged
- ▶ Always check the free speed of the machine after service. See Section Preparation before using the die grinder

The entire machine should be checked regularly at six-month intervals. If it is in heavy duty service or not running properly it should be taken out of service more often for inspection.

The strainer at the air inlet should be cleaned frequently to prevent clogging and decreased capacity.

## Useful information



Log in to Atlas Copco [www.atlascopco.com](http://www.atlascopco.com)

You can find information concerning our products, accessories, spare parts and published matters on our website.

## Ergonomic guidelines

1. Take frequent breaks and change work positions frequently.
2. Adapt the workstation area to your needs and the work task.
  - Adjust for convenient reach range by determining where parts or tools should be located to avoid static load.
  - Use workstation equipment such as tables and chairs appropriate for the work task.
3. Avoid work positions above shoulder level or with static holding during assembly operations.
  - When working above shoulder level, reduce the load on the static muscles by reducing the weight of the tool, using for example torque arms, hose reels or weight balancers. You can also reduce the load on the static muscles by holding the tool close to the body.
  - Make sure to take frequent breaks.
  - Avoid extreme arm or wrist postures, particularly for operations requiring a degree of force.

4. Adjust for convenient field of vision by minimizing movement of the eyes and head during the work task.
5. Use the appropriate lighting for the work task.
6. Select the appropriate tool for the work task.
7. Use ear protection equipment in noisy environments.
8. Use high-quality inserted tools or consumables to minimize exposure to excessive levels of vibrations.
9. Minimize exposure to reaction forces.
  - When cutting:  
A cut-off wheel can get stuck if the wheel is either bent or if it is not guided properly. Make sure to use correct flanges for cut-off wheels and avoid bending the wheel during cut-off operation.
  - When drilling:  
The drill might stall when the drill bit breaks through. Make sure you use support handles if the stall torque is too high. The safety standard ISO11148 part 3 recommends to use something to absorb the reaction torque above 10 Nm for pistol grip tools and 4 Nm for straight tools.
  - When using direct driven screw or nutrunners:  
Reaction forces depend on tool setting and joint characteristics. The ability to bear reaction forces depends on the operator's strength and posture. Adapt the torque setting to the operator's strength and posture and use a torque arm or reaction bar if the torque is too high.
10. Use dust extraction system or mouth protection mask in dusty environments.

## Country of origin

Please refer to the information on the product label.

## Spare parts

Parts without ordering number are not delivered separately for technical reasons.

The use of other than genuine Atlas Copco replacement parts may result in decreased tool performance and increased maintenance and may, at the company option, invalidate all warranties.

## Warranty

Contact the Atlas Copco sales representative within your area to claim a product. Warranty will only be approved if the product has been installed, operated and overhauled according to the Operating Instructions.

Please also see the delivery conditions applied by the local Atlas Copco company.

## ServAid

ServAid is a utility for providing updated product information concerning:

- Safety instructions
- Installation, Operation and Service instructions
- Exploded views

ServAid facilitates the ordering process of spare parts, service tools and accessories for the product of your choice. It is continuously updated with information of new and redesigned products.

You can use ServAid to present content in a specific language, provided translations are available, and to display information about obsolete products. ServAid offers an advanced search functionality of our entire product range.

ServAid is available on DVD and on the web:

<http://servaidweb.atlascopco.com>

For further information contact your Atlas Copco sales representative or e-mail us at:

[servaid.support@se.atlascopco.com](mailto:servaid.support@se.atlascopco.com)

# Service instructions

## Service instructions

### Operating instructions

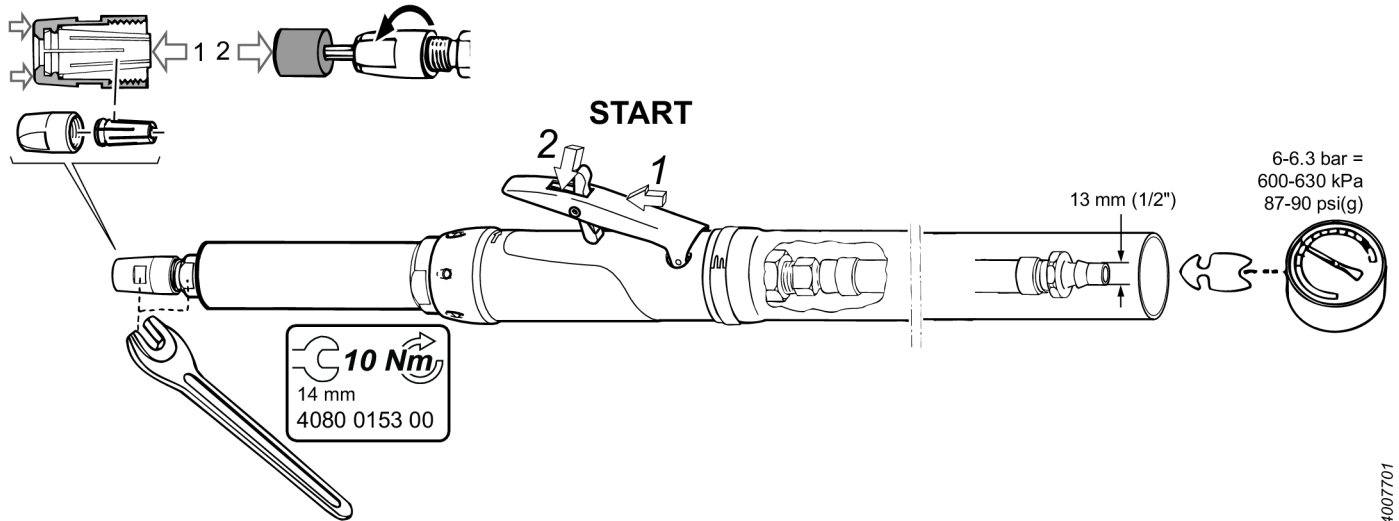

4007701

### Free speed

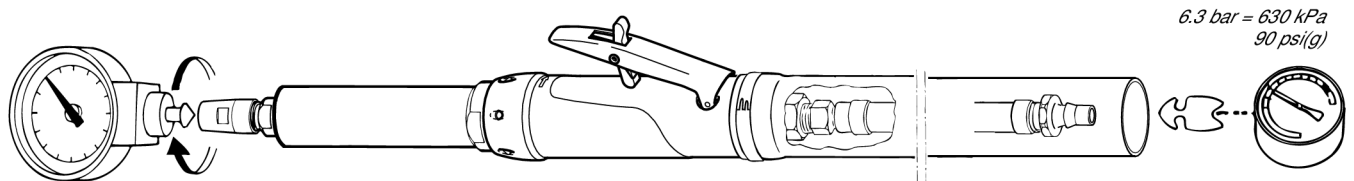

s008401

Model	Min r/min	Max r/min
G2427-S180	16000	18000

## Original Product Information

The Atlas Copco logo consists of the company name in a stylized, italicized serif font, centered between two thick, solid black horizontal bars.

**Atlas Copco Industrial  
Technique AB**  
SE-10523 STOCKHOLM  
Sweden  
Telephone: +46 8 743 95 00  
Telefax: +46 8 644 90 45  
[www.atlascopco.com](http://www.atlascopco.com)

© Copyright 2012, Atlas Copco Industrial Technique AB. All rights reserved. Any unauthorized use or copying of the contents or part thereof is prohibited. This applies in particular to trademarks, model denominations, part numbers and drawings. Use only authorized parts. Any damage or malfunction caused by the use of unauthorized parts is not covered by Warranty or Product Liability.

Out of respect to wildlife and nature, our technical literature is printed on environmentally friendly paper.